

RoHS

REV	ECN NO.	DESCRIPTION	DESIGN	APPROVAL	DATE
A1	NEW	更换图框			2023.11.25

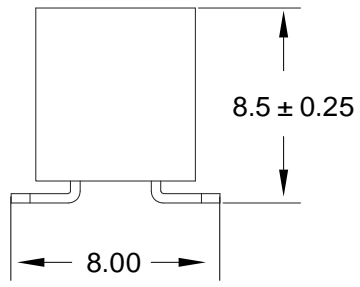
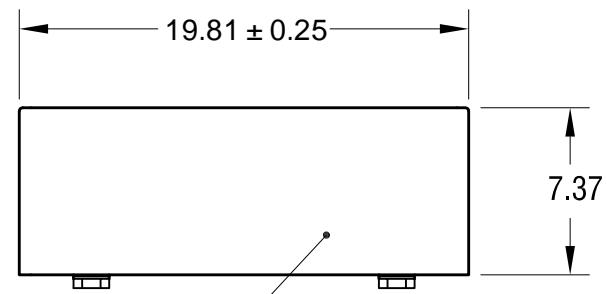
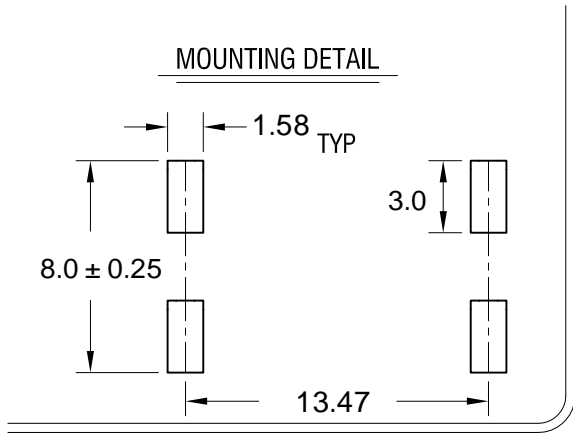
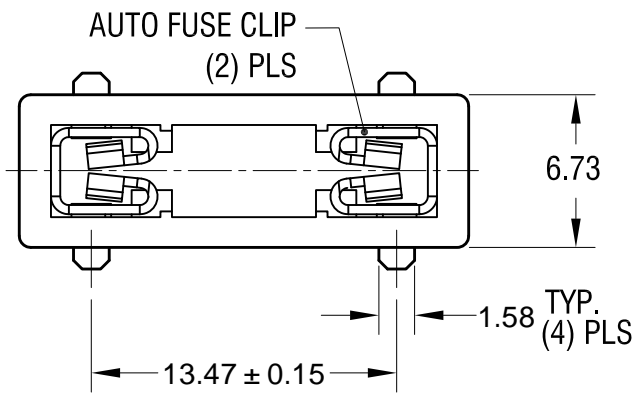

Product Characteristics

Blocks and Clips for Blade Fuses	
Compatible Fuses	Automotive Blade Fuses
Electrical Specifications	Rated Voltage: 500 V
	Rated Current: From 15 to 30 A
Molded Parts	Insulation Block: Black Thermoplastic PET (UL94 V-0) and PA66 (UL94 V-0)
Metal Parts	PCB Terminals: Tin Plated Cu Alloy
Electrical	Insulation Resistance: 10,000 Megaohm Minimum at 500 VDC
	Contact Resistance: ≤ 5 mΩ Maximum
Ambient Temperature	-40 °C to 125 °C

Ordering Code:

XF-508PVS-A-B
1 2 3

1. 序列号
2. 保险丝类型: A=大号
B=小号
3. 颜色码: B=黑色 (默认为空)
Y=黄色
R=红色
W=白色
O=橙色

ACTUAL SIZE

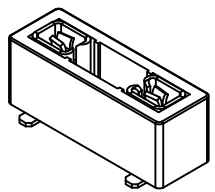

X.±0.50	x.°±	PART NO: XF-508PVS-A-B	XFCN 兴飞连接器			
.X±0.25	.X°±					
.XX±0.15	.xx°±	TITLE: AUTO BLADE FUSE HOLDERS	0769-82001899			
.XXX±0.10	.xxx°±		www.xfconn.com			
UNITS:	mm	DWG NO:	/			
THESE DRAWINGS AND SPECIFICATIONS ARE THE PROPERTY OF XFCN AND SHALL NOT BE REPRODUCED, COPIED OR CUED IN ANY MANNER WITHOUT THE PRIOR WRITTEN CONSENT OF XFCN		APPD				
		CHKD				
		DRAW	Wang	VIEW		
		DATE	2024.01.20	SCALE	SHEET	REV
			NONE	1:1	A1	