

RoHS

| | | | | | |
|-----|---------|-------------|--------|----------|------------|
| REV | ECN NO. | DESCRIPTION | DESIGN | APPROVAL | DATE |
| A1 | NEW | 更换图框 | | | 2024.05.24 |

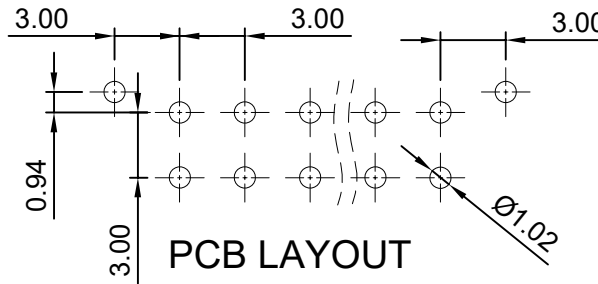
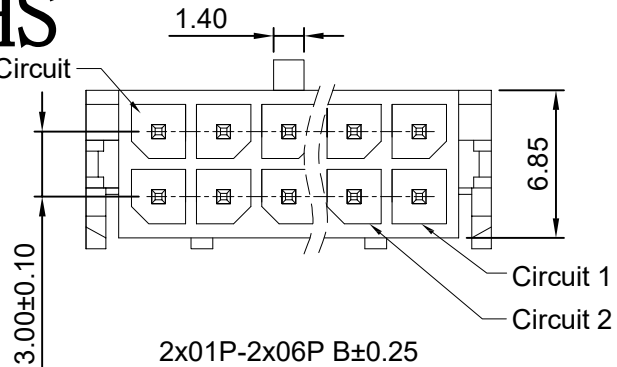

SPECIFICATIONS

1. Rated current: 5A AC, DC
2. Rating voltage: 250V AC DC
3. Temperature range: -25°C ~ +85°C
4. Insulation resistance: 1000MΩ Min.
5. Withstand voltage: 1500V AC/Minute
6. Contact resistance: 20mΩ Max.

Material:

Insulator Material: PA66 15%GF UL94V-0 Black
 Contact Material: Brass
 Contact Area Plating: tin-Plated

Ordering Code:

M3025V-2xNP
 1 2

1. 序列号
2. Pin位数: 2x02P
2x12P

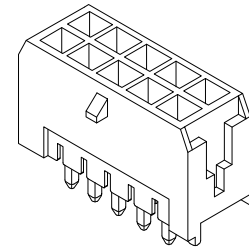
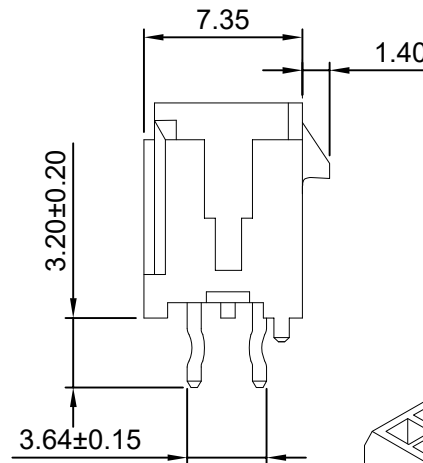
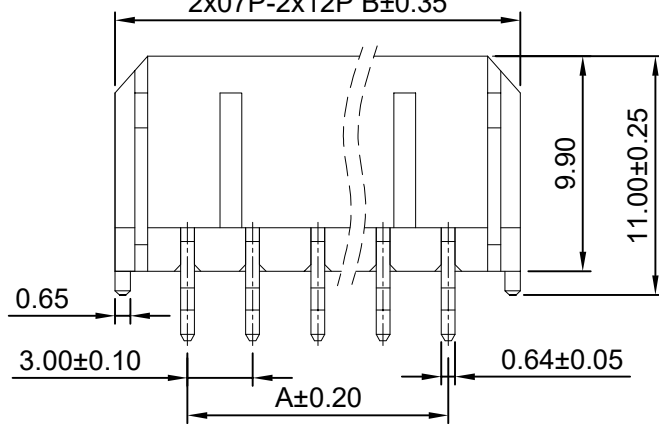

| No. of PIN/ROW | Dimension | |
|----------------|-----------|-------|
| | A | B |
| 2x01 | -- | 6.65 |
| 2x02 | 3.00 | 9.65 |
| 2x03 | 6.00 | 12.65 |
| 2x04 | 9.00 | 15.65 |
| 2x05 | 12.00 | 18.65 |
| 2x06 | 15.00 | 21.65 |
| 2x07 | 18.00 | 24.65 |
| 2x08 | 21.00 | 27.65 |
| 2x09 | 24.00 | 30.65 |
| 2x10 | 27.00 | 33.65 |
| 2x11 | 30.00 | 36.65 |
| 2x12 | 33.00 | 39.65 |

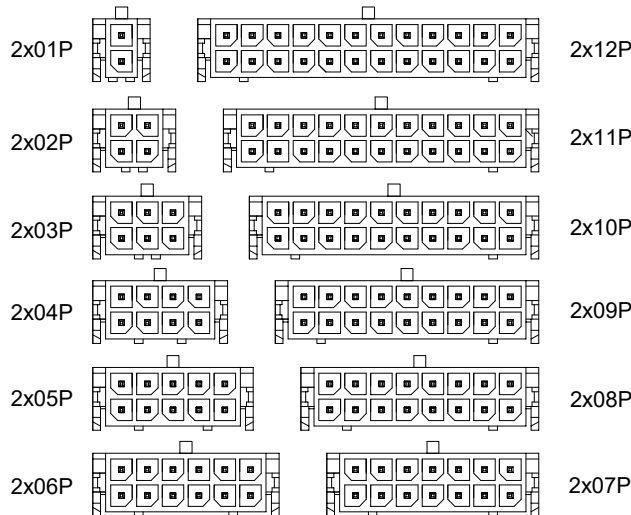

CIRCUIT SIZE LAYOUT

| | |
|-----------|--------|
| X.±0.50 | X.°± |
| .X±0.25 | .X°± |
| .XX±0.15 | .XX°± |
| .XXX±0.10 | .XXX°± |
| UNITS: | mm |

| | | | |
|--------------------------------------|----------------|-------------------|-----------|
| PART NO: M3025V-2xNP | | XFCN 兴飞连接器 | |
| TITLE: 3.00mm Crimp Style Connectors | | | |
| | | 0769-82001899 | |
| | | www.xfconn.com | |
| | | DWG NO: / | |
| APPD | Chen ZhiQiang | VIEW | |
| CHKD | Liu Wei | SCALE | SHEET REV |
| DRAW | Chen HongJiang | SCALE | 1/1 A1 |
| DATE | 2024.07.01 | NONE | |

THESE DRAWINGS AND SPECIFICATIONS ARE THE PROPERTY OF XFCN AND SHALL NOT BE REPRODUCED, COPIED OR CUED IN ANY MANNER WITHOUT THE PRIOR WRITTEN CONSENT OF XFCN