

# RoHS

REV.	ECN NO.	DESCRIPTION	DESIGN	APPROVAL	DATE
A1	NEW	更换图框			2023.09.03

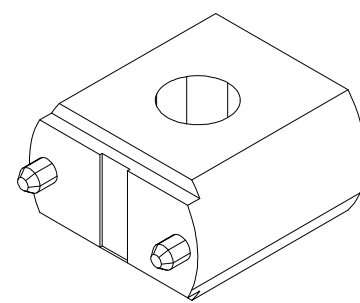

**Properties:**  
 Material: Brass  
 Surface: Tin  
 Solder Cream Thickness: 120 μm  
 Tightening Torque: 0.4 Nm  
 Operating Temperature: -55 °C up to +150 °C  
 Rated Current: 50A

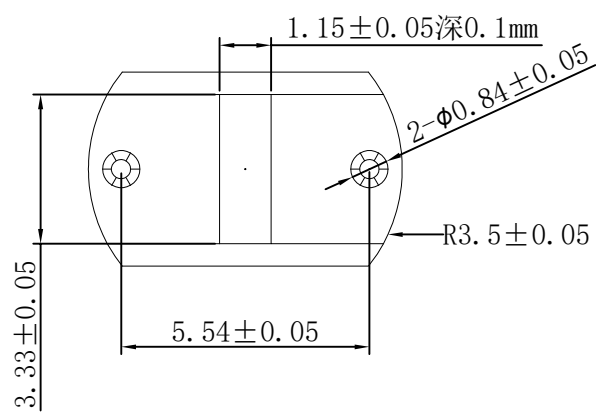
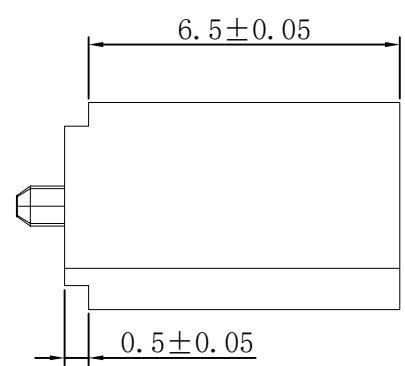
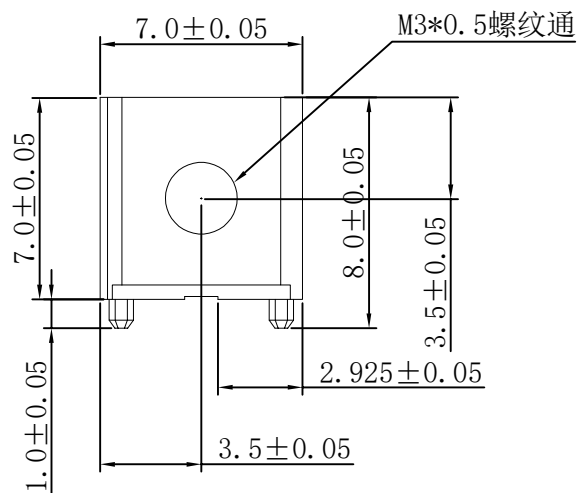

### Packaging Properties:

Packaging	Tape and Reel
Packaging Unit (Qty.)	1000

>30.±0.4	X.°±	PART NO: TM374663	<b>XFCN 兴飞连接器</b>					
6-30±0.3	.X°±					TITLE: PCB SOLDERING TERMINAL	0769-82001899	
0-6±0.2	.XX°±						www.xfconn.com	
ANGLES±1°	.XXX°±					DWG NO: /		
UNITS:	mm	APPD	Chen ZhiQiang	VIEW	⊕ □			
THESE DRAWINGS AND SPECIFICATIONS ARE THE PROPERTY OF XFCN AND SHALL NOT BE REPRODUCED, COPIED OR CUED IN ANY MANNER WITHOUT THE PRIOR WRITTEN CONSENT OF XFCN		CHKD	Liu Wei	SCALE	SHEET			
		DRAW	Chen HongJiang		REV			
		DATE	2024.04.23	NONE	1/1	A1		

序号	名称	零件编号	材质	数量