

RoHS

REV	ECN NO.	DESCRIPTION	DESIGN	APPROVAL	DATE
A1	NEW	更换图框			2023.11.25

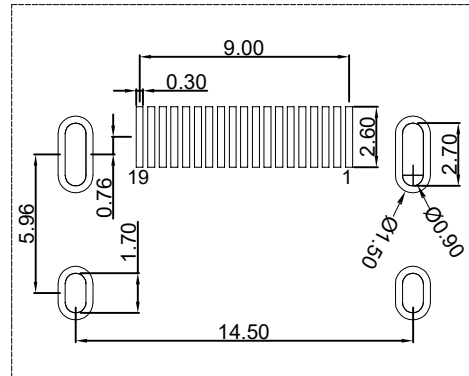

RECOMMENDED PCB HOLE LAYOUT
COMPONENT SIDE VIEW(TOLERANCE:±0.05)

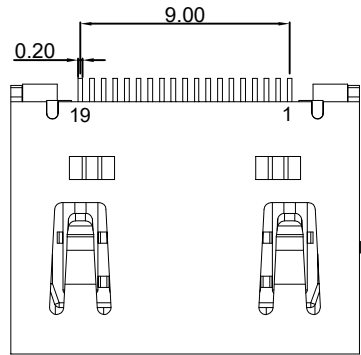
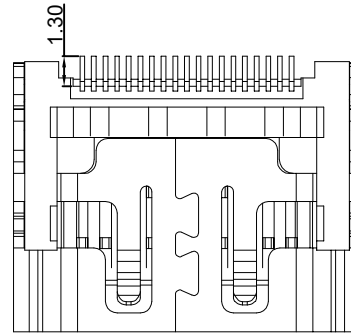
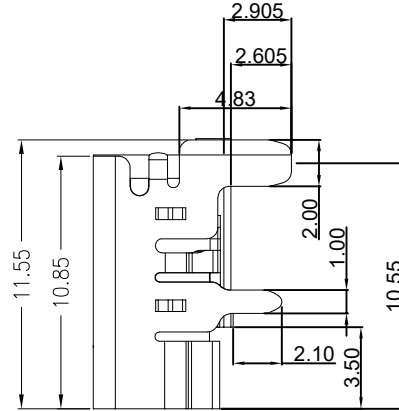
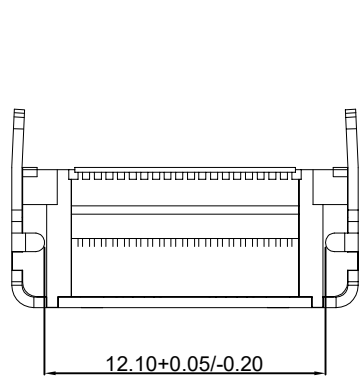
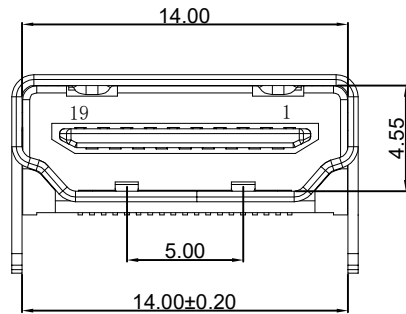

特性: Specifications:

电器: Electrical:

接触阻抗: Contact Resistance 30 milliohms Max

耐电压: Dielectric Withstanding Voltage: 500VAC Sea Level

绝缘阻抗: Insulation Resistance: 100 MEGA ohms MIN

材料: Material:

塑胶Housing: High Temperature Thermoplastics. LCP UL94V-0 Black

端子: Contact: Copper Alloy 铜合金铜壳

电镀Finish: 端子Contact: Gold plating on contact area, tin plating on welding feet

接触区域镀金 焊脚镀锡

外壳: shell: SPCC 铁壳

电镀Finish: 外壳: shell Nickel plating

X. 0.3	X.°±
. XX±0.2	. XX°±
. XX±0.08	. XX°±
. XXX±0.03	. XXX°±
UNITS:	mm

THESE DRAWINGS AND SPECIFICATIONS ARE THE PROPERTY OF XFCN AND SHALL NOT BE REPRODUCED, COPIED OR CUED IN ANY MANNER WITHOUT THE PRIOR WRITTEN CONSENT OF XFCN

PART NO:		HDA65-N1S1-4000-A		XFCN 兴飞连接器	
TITLE:		HDMI A TYPE 包胶铁壳长脚 无字无凸 镀镍		0769-82001899	
				www.xfconn.com	
UNITS:		mm		DWG NO: /	
APPD	Chen ZhiQiang	VIEW			
CHKD	Liu Wei	SCALE			
DRAW	Chen HongJiang	SHEET	1/2	REV	
DATE	2024.08.13	NONE	1/2	A1	

RoHS

REV	ECN NO.	DESCRIPTION	DESIGN	APPROVAL	DATE
A1	NEW	更换图框			2023.11.25

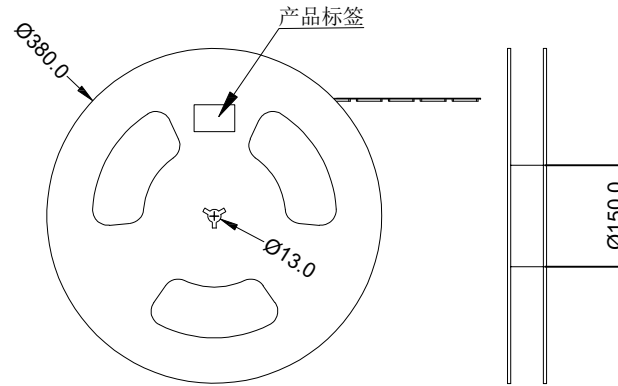
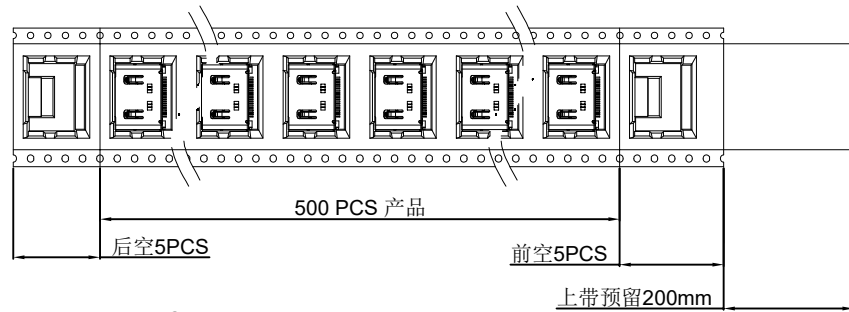
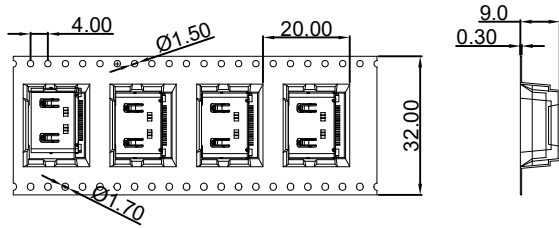

NO.1

NO.2

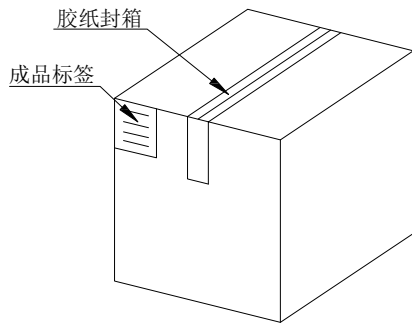

纸箱规格: 395*395*190

NO.4

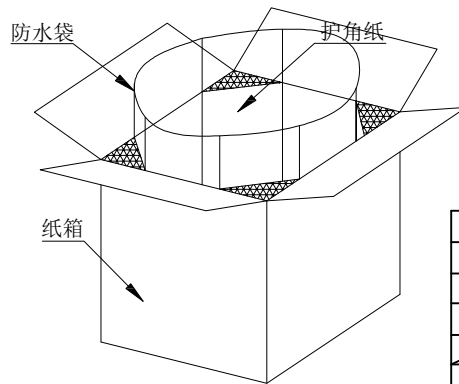
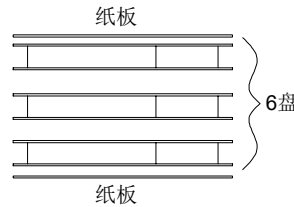

NO.3

1. 材质要求:

- 1.1 纸箱的材质要求为K-K;外形尺寸为39.5*39.5*19.5CM;
- 1.2 卷盘的材质为PS;卷盘的外形尺寸为 $\phi 380 \times 48.2$;
- 1.3 卷带的材质为PS;卷带的外形尺寸为10200*32.00*9.10mm

2. 包装要求:

- 2.1 将卷带放入包装机后, 前空5PCS, 后放产品500PCS, 再后空5PCS; 上带留 200MM长度。
- 2.2 将包装好的产品从包装机上取下并包装好;
- 2.3 把累叠好的6盘(共计3Kset), 用防水袋包装内附干燥剂, 上下放纸板放入纸箱内;
- 2.4 把包装好的成品打包封箱, 并在纸箱外贴上标签

备注:

1. 若有未装满之零数, 必须用泡棉塞满 2. 针对于包装方式可根据客户要求包装。

X. 0.3	X. °±	PART NO:		HDA65-N1S1-4000-A		XFCN 兴飞连接器	
. X ± 0.2	. X ° ±	TITLE:		HDMI A TYPE 包胶铁壳长脚 无字无凸 镀镍		0769-82001899	
. XX ± 0.08	. XX ° ±	UNITS:		mm		www.xfconn.com	
. XXX ± 0.03	. XXX ° ±	DATE		2024.08.13		DWG NO: /	
THESE DRAWINGS AND SPECIFICATIONS ARE THE PROPERTY OF XFCN AND SHALL NOT BE REPRODUCED, COPIED OR CUED IN ANY MANNER WITHOUT THE PRIOR WRITTEN CONSENT OF XFCN		APPD	Chen ZhiQiang	VIEW			
		CHKD	Liu Wei	SCALE	SHEET	REV	
		DRAW	Chen HongJiang	NONE	2/2	A1	